



■ Features :

- Universal AC input / Full range (up to 295VAC)
- High efficiency 91%
- Protections: Short circuit / Overload / Over voltage / Over temperature
- Built-in active PFC function
- Cooling by free air convection
- OCP point adjustable through output cable or internal potential meter
- Suitable for LED lighting and moving sign applications
- IP65 / IP67 design for indoor or outdoor installations
- Compliance to worldwide safety regulations for lighting
- 3 years warranty



CLG-150-12 **A** Blank : IP67 rated. Cable for I/O connection.  
 A : IP65 rated. Output voltage and constant current level can be adjusted through internal potential meter.  
 B : IP67 rated. Constant current level adjustable through output cable.  
 C : Terminal block for I/O connection. Output voltage and constant current level can be adjusted through internal potential meter.

**SPECIFICATION**

MODEL	CLG-150-12	CLG-150-15	CLG-150-20	CLG-150-24	CLG-150-30	CLG-150-36	CLG-150-48		
OUTPUT	DC VOLTAGE	12V	15V	20V	24V	30V	36V	48V	
	CONSTANT CURRENT REGION Note.4	9 ~ 12V	11.25 ~ 15V	15 ~ 20V	18 ~ 24V	22.5 ~ 30V	27 ~ 36V	36 ~ 48V	
	RATED CURRENT	11A	9.5A	7.5A	6.3A	5A	4.2A	3.2A	
	RATED POWER	132W	142.5W	150W	151.2W	150W	151.2W	153.6W	
	RIPPLE & NOISE (max.) Note.2	150mVp-p	150mVp-p	150mVp-p	150mVp-p	150mVp-p	150mVp-p	200mVp-p	
	VOLTAGE ADJ. RANGE Note.6	9 ~ 13V	13 ~ 17V	17 ~ 22V	22 ~ 27V	26 ~ 32V	31 ~ 41V	40 ~ 56V	
	CURRENT ADJ. RANGE	Can be adjusted by internal potential meter or through output cable							
		5.5 ~ 11A	4.75 ~ 9.5A	3.75 ~ 7.5A	3.15 ~ 6.3A	2.5 ~ 5A	2.1 ~ 4.2A	1.6 ~ 3.2A	
	VOLTAGE TOLERANCE Note.3	±2.0%	±2.0%	±2.0%	±1.0%	±1.0%	±1.0%	±1.0%	
	LINE REGULATION	±0.5%	±0.5%	±0.5%	±0.5%	±0.5%	±0.5%	±0.5%	
LOAD REGULATION	±1.0%	±1.0%	±1.0%	±0.5%	±0.5%	±0.5%	±0.5%		
SETUP, RISE TIME	3000ms, 80ms at full load 230VAC / 115VAC								
HOLD UP TIME (Typ.)	50ms / 230VAC 16ms / 115VAC at full load								
INPUT	VOLTAGE RANGE Note.5	90 ~ 295VAC		127 ~ 417VDC					
	FREQUENCY RANGE	47 ~ 63Hz							
	POWER FACTOR	PF ≥ 0.95/230VAC PF ≥ 0.98/115VAC at full load and rated output voltage				PF ≥ 0.9 at 75 ~ 100% load			
	EFFICIENCY (Typ.)	88%	88%	90%	90%	91%	91%	91%	
	AC CURRENT	2A / 115VAC		1A / 230VAC					
	INRUSH CURRENT(max.)	COLD START 65A/230VAC							
LEAKAGE CURRENT	<1mA / 240VAC								
PROTECTION	OVER CURRENT (Typ.) Note.4	95 ~ 108% Protection type : Constant current limiting, recovers automatically after fault condition is removed							
	SHORT CIRCUIT	Hiccup mode, recovers automatically after fault condition is removed							
	OVER VOLTAGE	13.5 ~ 16V	18 ~ 20V	23 ~ 27V	28 ~ 34V	33 ~ 36V	42 ~ 48V	57 ~ 65V	
	OVER TEMPERATURE	100°C ±10°C (RTH2) Protection type : Shut down o/p voltage, re-power on to recover							
ENVIRONMENT	WORKING TEMP.	-30 ~ +70°C (Refer to output load derating curve)							
	WORKING HUMIDITY	20 ~ 95% RH non-condensing							
	STORAGE TEMP., HUMIDITY	-40 ~ +80°C, 10 ~ 95% RH							
	TEMP. COEFFICIENT	±0.03%/°C (0 ~ 50°C)							
	VIBRATION	10 ~ 500Hz, 5G 12min./1cycle, period for 72min. each along X, Y, Z axes							
SAFETY & EMC	SAFETY STANDARDS Note.7	UL8750, UL1012 ; EN61347-1, EN61347-2-13 independent (except for CLG-150 C type) ; UL60950-1, TUV EN60950-1 ; J61347-1(option, except for CLG-150 C type), J61347-2-13, IP65 or IP67 approved							
	WITHSTAND VOLTAGE	I/P-O/P:3.75KVAC I/P-FG:1.88KVAC O/P-FG:0.5KVAC							
	ISOLATION RESISTANCE	I/P-O/P, I/P-FG, O/P-FG:100M Ohms / 500VDC / 25°C / 70% RH							
	EMI CONDUCTION & RADIATION	Compliance to EN55015, EN55022 (CISPR22) Class B							
	HARMONIC CURRENT	Compliance to EN61000-3-2 Class C (≥ 75% load) ; EN61000-3-3							
	EMS IMMUNITY	Compliance to EN61000-4-2,3,4,5,6,8,11; ENV50204, EN61547, EN55024, light industry level (surge 4KV), criteria A							
OTHERS	MTBF	303.7Khrs min. MIL-HDBK-217F (25°C)							
	DIMENSION	222.2*68*38.8mm (L*W*H)(CLG-150-Blank/A/B)		229*68*38.8mm (L*W*H)(CLG-150-C)					
	PACKING	1.0Kg; 12pcs/13Kg/0.49CUFT(CLG-150-Blank/A/B)		1Kg; 12pcs/13Kg/0.96CUFT(CLG-150-C)					
NOTE	<ol style="list-style-type: none"> <li>1. All parameters NOT specially mentioned are measured at 230VAC input, rated load and 25 °C of ambient temperature.</li> <li>2. Ripple &amp; noise are measured at 20MHz of bandwidth by using a 12" twisted pair-wire terminated with a 0.1uf &amp; 47uf parallel capacitor.</li> <li>3. Tolerance : includes set up tolerance, line regulation and load regulation.</li> <li>4. Constant current operation region is within 75% ~100% rated output voltage. This is the suitable operation region for LED related applications, but please reconfirm special electrical requirements for some specific system design.</li> <li>5. Derating may be needed under low input voltages. Please check the static characteristics for more details.</li> <li>6. Type A and type C only.</li> <li>7. Safety and EMC design refer to EN60598-1, subject 8750(UL), CNS15233, GB7000.1, FCC part18.</li> <li>8. The power supply is considered as a component that will be operated in combination with final equipment. Since EMC performance will be affected by the complete installation, the final equipment manufacturers must re-qualify EMC Directive on the complete installation again.</li> </ol>								

■ Mechanical Specification

Case No. 954A Unit:mm

Blank:(CLG-150)

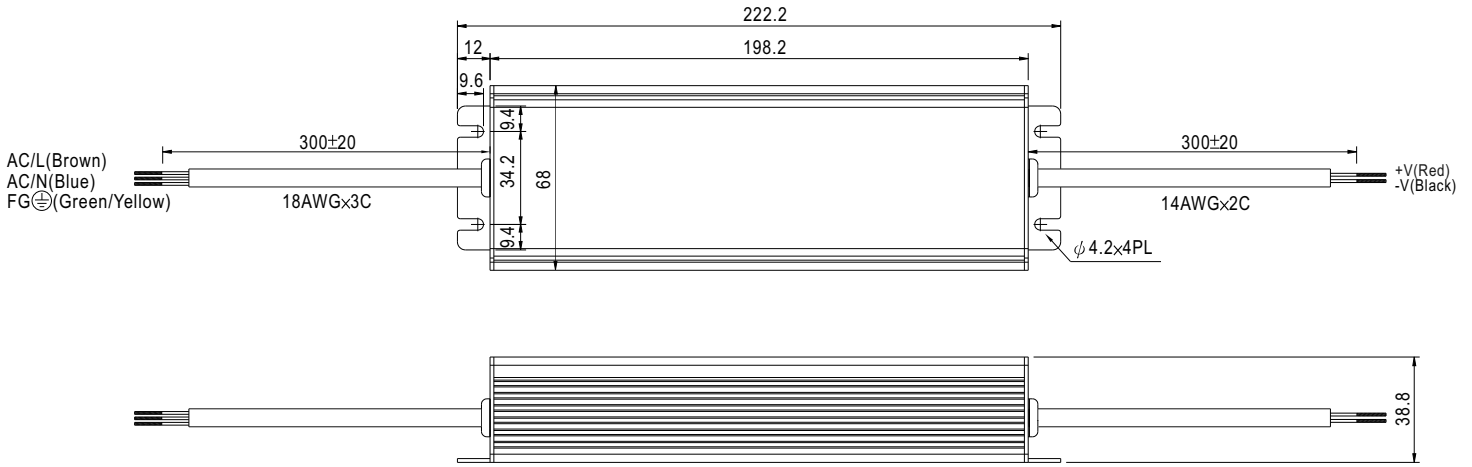

※IP67 rated. Cable for I/O connection.

A Type:(CLG-150- \_A)

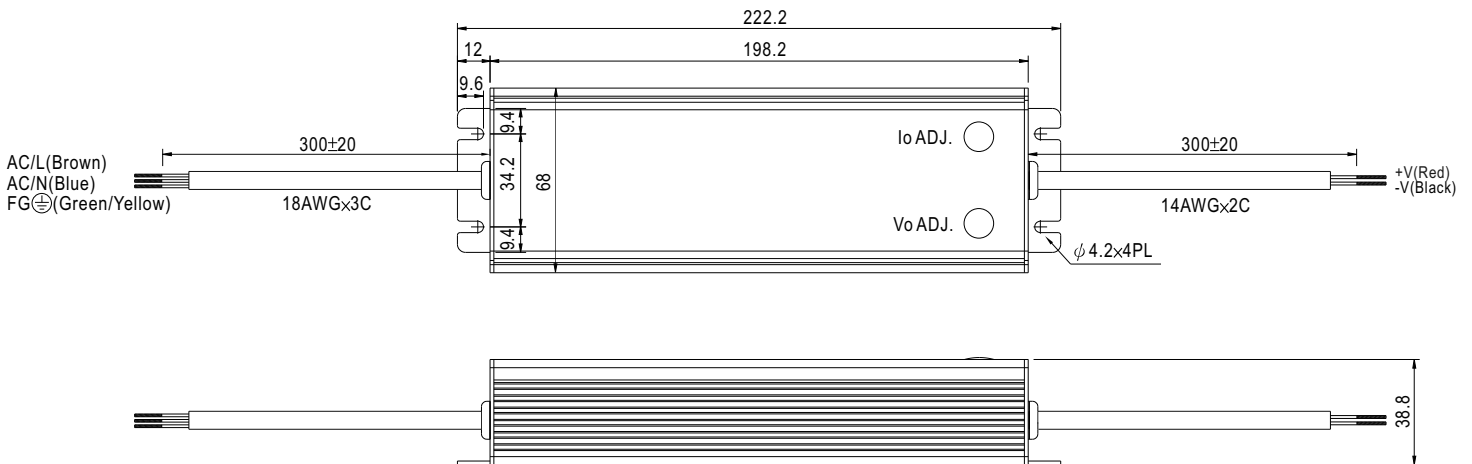

※ IP65 rated. Output voltage and constant current level can be adjusted through internal potential meter.  
(Can access by removing the rubber stopper on the case.)

**B Type:(CLG-150-B)**

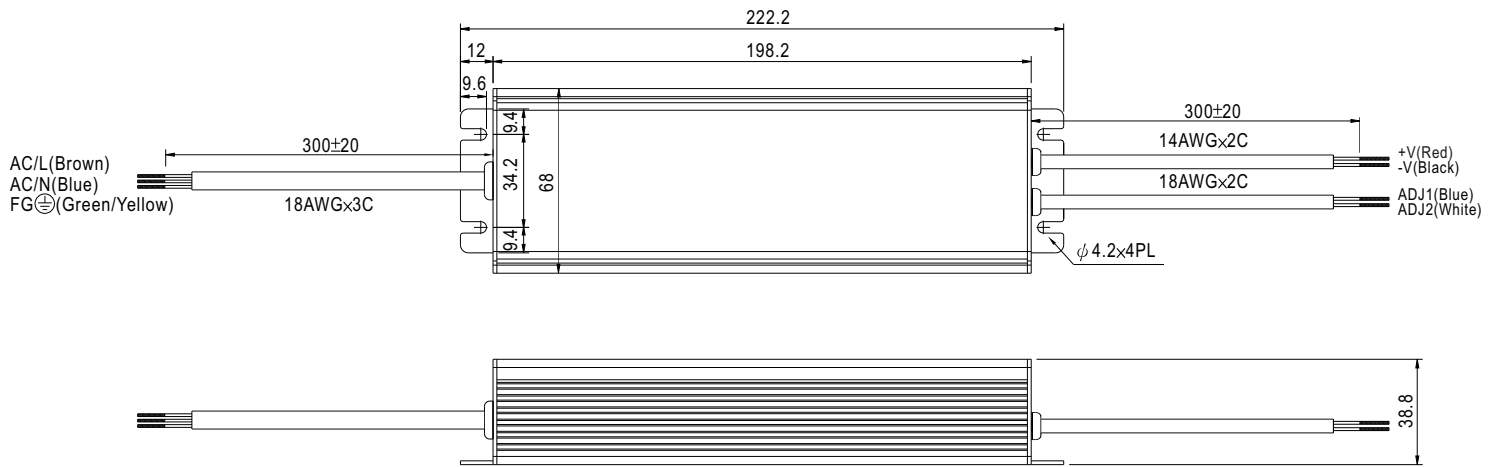

- ※ IP67 rated. Output constant current level can be adjusted through output cable by connecting a resistor between ADJ1 and ADJ2.
- ※ Reference resistance value for output current adjustment (Typical)

Resistance	Percentage of rated current
Open	Slightly > 100%
4.7KΩ	100%
620Ω	75%
82Ω	50%
Short	Slightly < 50%

**C Type:(CLG-150-C)**

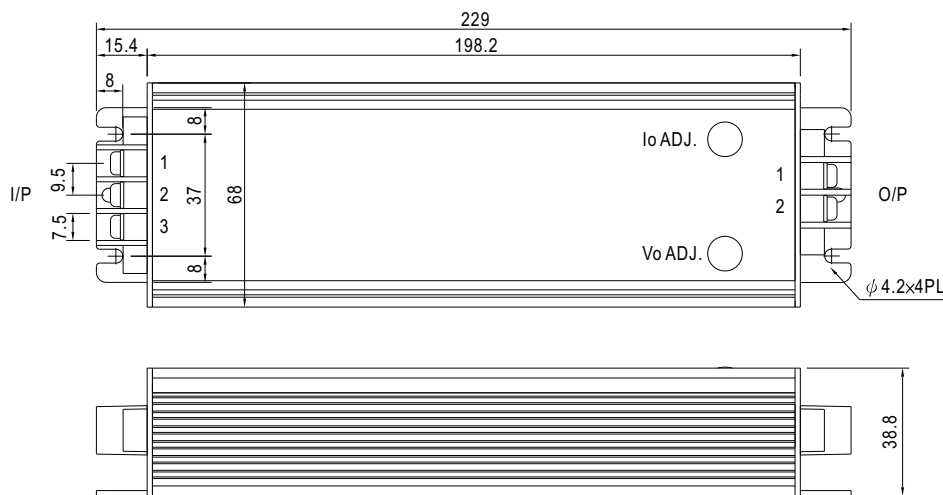

AC Input Terminal Pin No. Assignment

Pin No.	Assignment
1	FG $\perp$
2	AC/N
3	AC/L

DC Output Terminal Pin No. Assignment

Pin No.	Assignment
1	+V
2	-V

- ※ Output voltage and constant current level can be adjusted through internal potential meter. (Can access by removing the rubber stopper on the case.)

**Block Diagram**

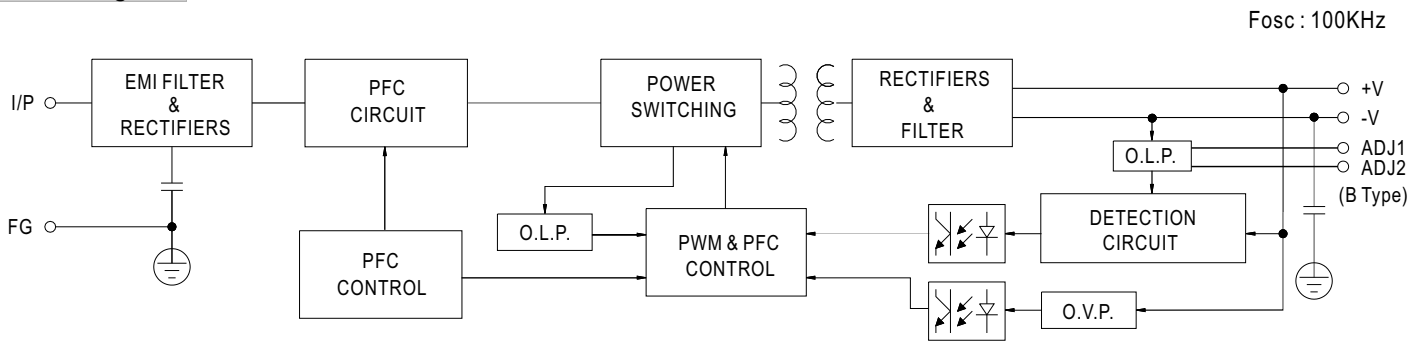

**Derating Curve**

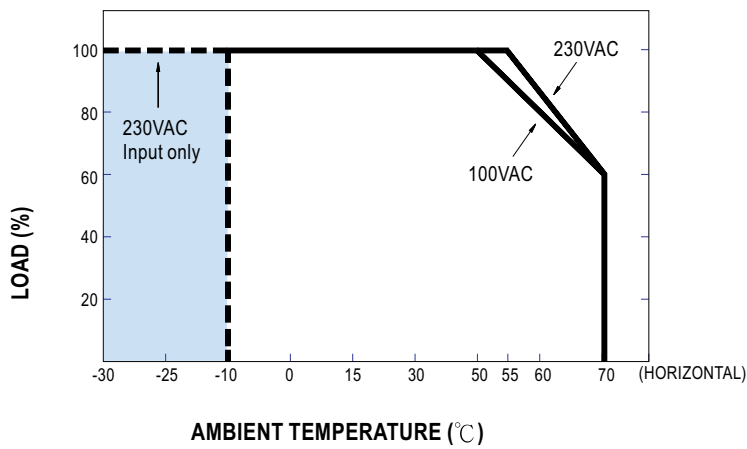

**Static Characteristics**

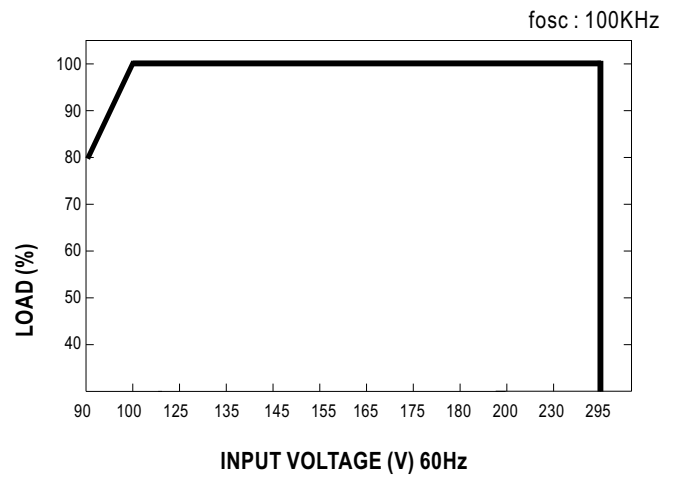

**Power Factor Characteristic**

Power factor will be higher than 0.9 when output loading is 75% or higher.

**Constant Current Mode**

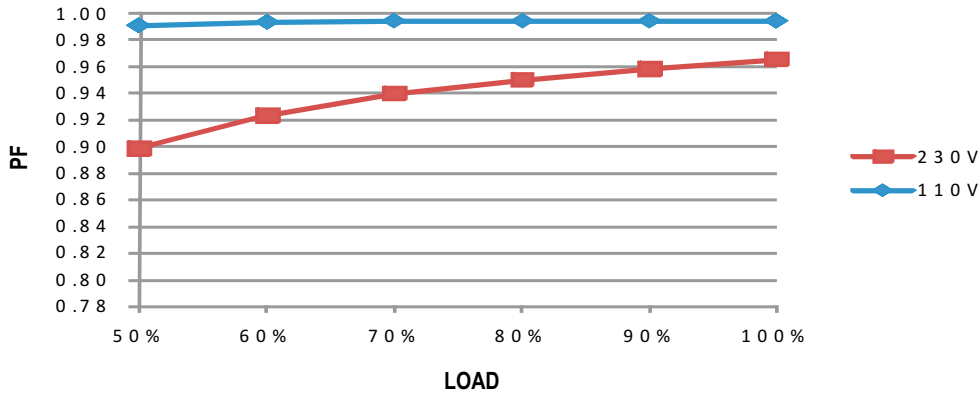

**EFFICIENCY vs LOAD (48V Model)**

CLG-150 series possess superior working efficiency that up to 91% can be reached in field applications.

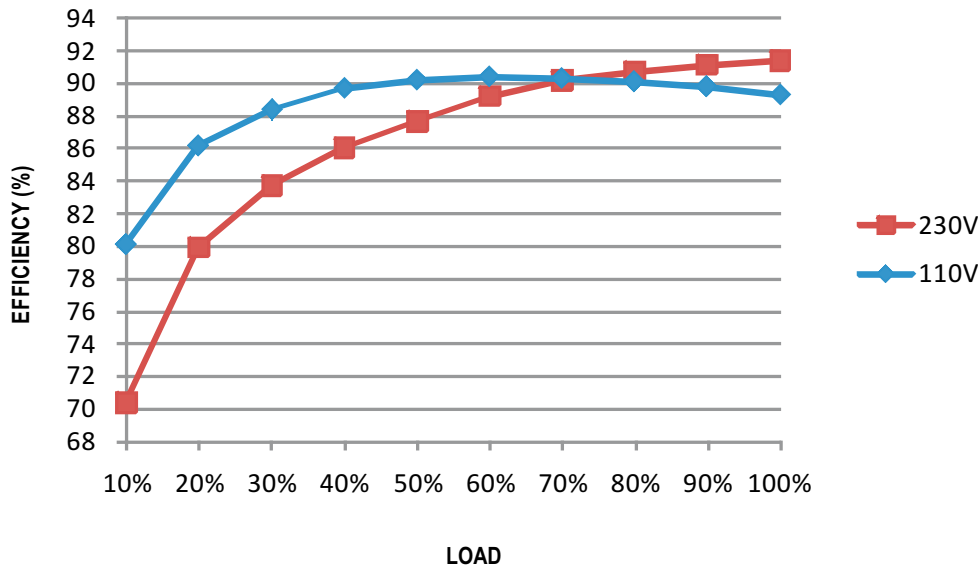

**DRIVING METHODS OF LED MODULE**

There are two major kinds of LED drive method "direct drive" and "with LED driver".

A typical LED power supply may either work in "constant voltage mode (CV) or constant current mode (CC)" to drive the LEDs.

Mean Well's LED power supply with CV+ CC characteristic can be operated at both CV mode [with LED driver, at area (A)] and CC mode [direct drive, at area (B)].

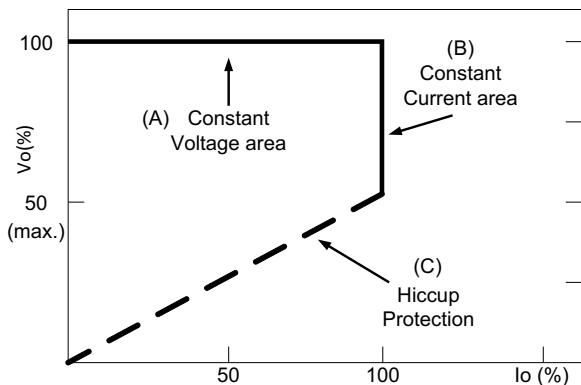

Typical LED power supply I-V curve